

SolarMount[®]

PV's most versatile mounting system



Ground Mounted Solution



Roof Mounted Solution



Open Structure Solution

Google Campus, California
© 2007, courtesy of El Solutions Inc.

SolarMount is the most versatile PV mounting rail system on the market today.

We've engineered installer-friendly components for maximum flexibility, allowing you to solve virtually any PV mounting challenge.

The universal SolarMount rail system has three options which can be assembled into a wide variety of PV mounting structures to accommodate any job site.

Unirac provides a technical support system complete with installation and code compliance documentation, an on-line estimator and design assistance to help you solve the toughest challenges.



Visit us online at www.unirac.com

SOLARMOUNT® RAIL OPTIONS

PV's most versatile mounting system

SolarMount® HD

HD (heavy duty) rail adds the SolarMount advantage to PV PoleTops®, U-LAs (see separate data sheets), and custom applications that require long spans.

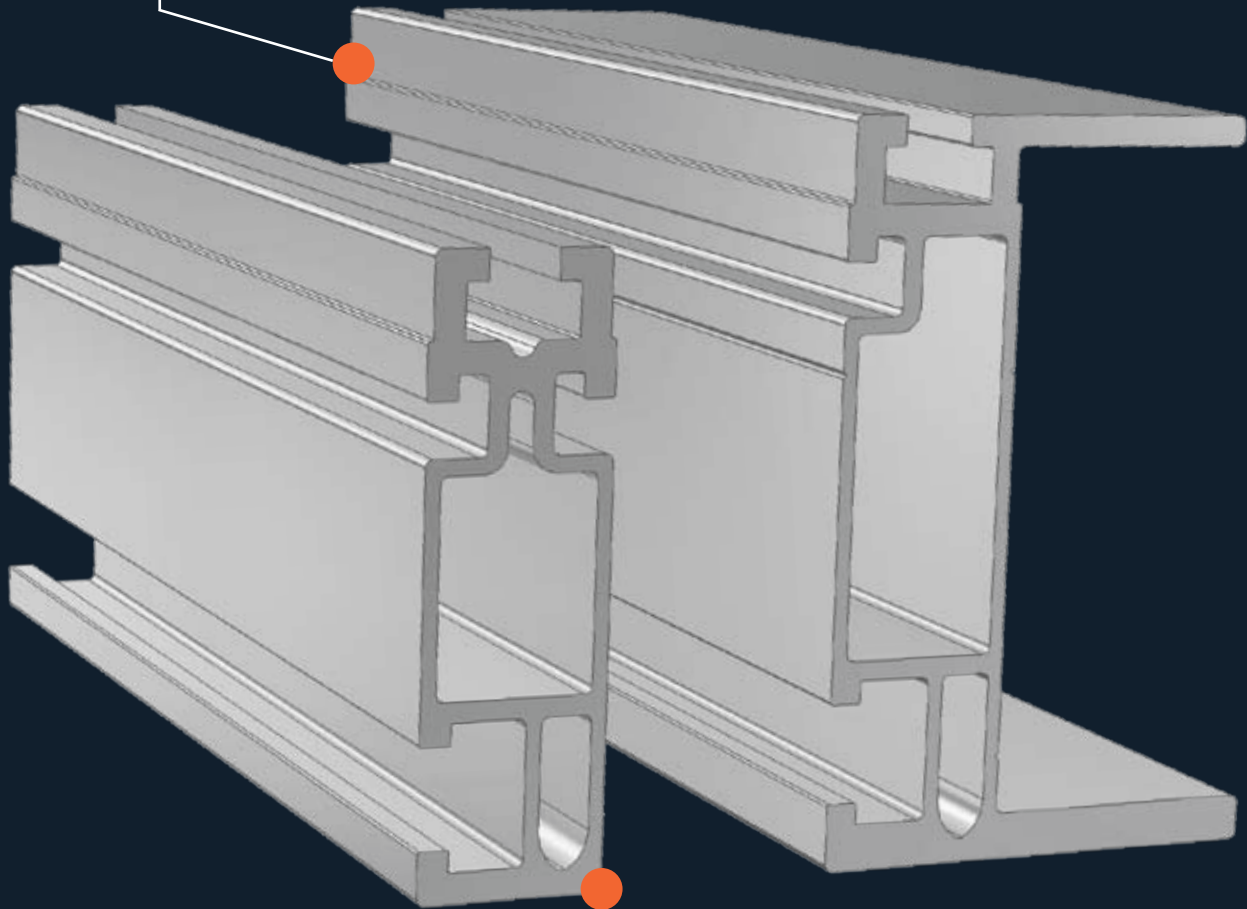

Standard SolarMount®

Standard rail gives you ultimate flexibility, including bottom mounting and tilt-up options.

MODULE MOUNTING

Assembly Sequence Is Your Choice

Top Mounting Clamps

Ideal for flush mount applications, such as residential rooftops, where it is most convenient to secure footings and rails before installing modules, top mounting clamps securely grip any point of the module frame, freeing you from the constraints of module mounting holes.

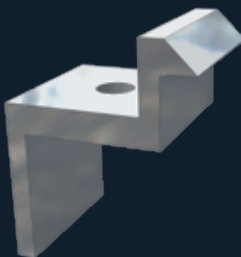

Bottom Mounting Clips

Use bottom mounting clips (standard and HD rail only) whenever you prefer to preassemble the array using module mounting holes. Simply fit the clip into its rail slot over the mounting bolt for a secure connection. Adjust the clip position anywhere along the rail slot.



ATTACHMENT OPTIONS

Flexible Components Speed Installation

Standoffs

Use standoffs whenever flashed installations are required, on tile roofs, for example. Two-piece aluminum standoff allow precise placement of a flashing over a secured base prior to the installation of the standoff itself.

All standoff types come in four standard heights: 3, 4, 6, and 7 inches. Appropriate flashings are available.

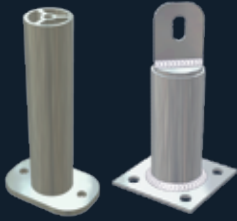

Serrated L-feet

Standard for ground mount installations on residential and commercial rooftops, use L-feet alone above asphalt composition shingles or in conjunction with flat top standoffs. Mount standard or light rails. Configure to either of two rail heights, one promoting air flow for cooling, the other offering close-to-the-roof aesthetics

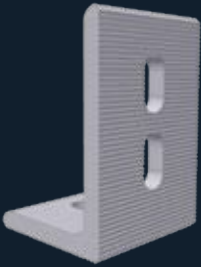

Strut-in-Tube Style Legs

Quickly set the precise tilt angle required. Styles are available for high profile (1 or 2 legs per rail) and low profile installations.

Each series offers three leg lengths so that you can adjust to exactly the tilt angle you want—up to a maximum of 60 degrees—without cutting and drilling at the job site.



FastFoot™

The FastFoot™ attachment features Eco-Fasten technology by the Alpine Snow Guard Company, allowing attachments to metal, concrete and wood decks without compromising the integrity of the roof.

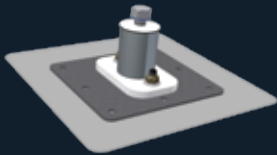

Tile Hook

Made from cast aluminum, the tile hook attachment provides SolarMount with a cost-effective solution for barrel or Spanish tile roofs. All required lag bolts and hardware are included. Refer to the tile hook engineering data for max load capabilities.



KEY BENEFITS

of SolarMount® Rail

Maximum flexibility

- Flush, high-profile or low-profile configurations
- Roof or ground mount
- Pitched or flat roof

Ease of installation

- Installer-friendly components
- Minimized penetration with longer attachment spans than competitive products
- Designed with customer input
- Grounding and wire management options

Complete technical support

- Installation and code compliance documentation
- Online estimator
- Person-to-person customer service

Core component for Unirac mounting solutions

- Three rail options to accommodate any job site
- Incorporated into other major product lines

Bright Thinking in Solar



Component Specifications

6061-T6 and 6063-T5

- SolarMount ballast frame

6105-T5 aluminum extrusion

- SolarMount® rails
- Mounting clips and clamps
- Tilt legs and L-feet
- Two-piece standoffs

Severe Condition 4 (very severe)
zinc-plated welded steel

- One-piece standoffs

18-8 stainless steel

- Fasteners

Code Compliant

The SolarMount® system is PE certified.
Call Unirac for documentation applicable
to your building code

Warranty

SolarMount® is covered by a 10-year limited
product warranty and a 5-year limited finish
warranty.

For complete warranties, download any
SolarMount® installation manual from
our web site.



Visit us online at www.unirac.com